

1

2

3

4

5

6

7

RoHS Compliant

305±15

P1

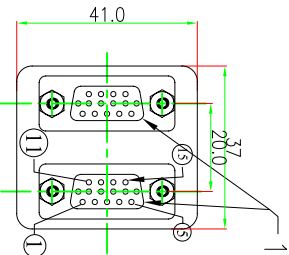

HD15F-HD15F

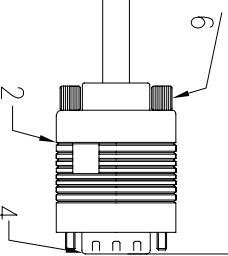
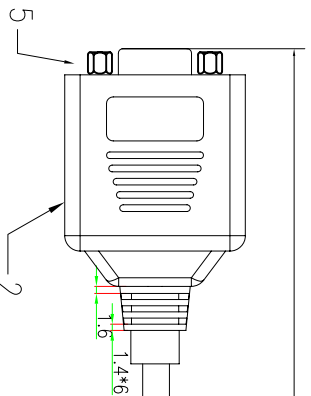

P2

HD15M

Signature	Revision History	Date	Rev.
Norman Xu	First Release	sep.18.2007	01

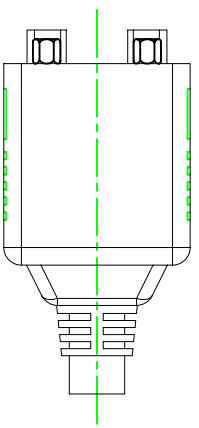

PIN ASSIGNMENT			
HD15M	HD15F	HD15F	HD15F
1	1	1	1
2	2	2	2
3	3	3	3
4	4	4	4
5	5	5	5
6	6	6	6
7	7	7	7
8	8	8	8
9	9	9	9
10	10	10	10
11	11	11	11
12	12	12	12
13	13	13	13
14	14	14	14
15	15	15	15
SHELL	SHELL	SHELL	SHELL

A	1	2	3	4	5	6	7																																	
B																																								
C																																								
D																																								
E																																								
F																																								
G	<table border="1"> <tr><td>6</td><td>THUMB SCREW #4-40UNC PLATED:GOLD ABS COLOR:BLACK</td><td>PCS</td><td>2</td></tr> <tr><td>5</td><td>THUMB NUT #4-40UNC PLATED:GOLD</td><td>PCS</td><td>2</td></tr> <tr><td>4</td><td>HIGH DENSITY D-SUB 15P MALE PLATED: GOLD</td><td>PCS</td><td>1</td></tr> <tr><td>3</td><td>UL2919 28AWG*3C+28AWG*9C+AM+D+B ODS.5 COLOR:BLACK</td><td></td><td></td></tr> <tr><td>2</td><td>PVC MOLDED BLACK IN COLOR</td><td></td><td></td></tr> <tr><td>1</td><td>HIGH DENSITY D-SUB 15P FEMALE PLATED: GOLD</td><td>PCS</td><td>2</td></tr> </table>				6	THUMB SCREW #4-40UNC PLATED:GOLD ABS COLOR:BLACK	PCS	2	5	THUMB NUT #4-40UNC PLATED:GOLD	PCS	2	4	HIGH DENSITY D-SUB 15P MALE PLATED: GOLD	PCS	1	3	UL2919 28AWG*3C+28AWG*9C+AM+D+B ODS.5 COLOR:BLACK			2	PVC MOLDED BLACK IN COLOR			1	HIGH DENSITY D-SUB 15P FEMALE PLATED: GOLD	PCS	2	<table border="1"> <tr><td>No.</td><td>DESCRIPTION</td><td>UNIT</td><td>QTY</td></tr> <tr><td>1</td><td></td><td></td><td></td></tr> </table>				No.	DESCRIPTION	UNIT	QTY	1			
6	THUMB SCREW #4-40UNC PLATED:GOLD ABS COLOR:BLACK	PCS	2																																					
5	THUMB NUT #4-40UNC PLATED:GOLD	PCS	2																																					
4	HIGH DENSITY D-SUB 15P MALE PLATED: GOLD	PCS	1																																					
3	UL2919 28AWG*3C+28AWG*9C+AM+D+B ODS.5 COLOR:BLACK																																							
2	PVC MOLDED BLACK IN COLOR																																							
1	HIGH DENSITY D-SUB 15P FEMALE PLATED: GOLD	PCS	2																																					
No.	DESCRIPTION	UNIT	QTY																																					
1																																								
H	<table border="1"> <tr><td>1</td><td></td><td></td><td></td></tr> </table>				1				<table border="1"> <tr><td>1</td><td></td><td></td><td></td></tr> </table>				1																											
1																																								
1																																								

Drawn by	Sep.18.2007	Norman Xu	ASSMANN Electronic GmbH	Part No. AK 513001
Checked by	Sep.18.2007	Alex Dan		
Approved by	Sep.18.2007	Thorsten Alderman		
Title:			VGA SPLITTER:VGA MALE TO 2*VGA F.	
Scale	N/A	Sheet	1/1	
Unit	MM			

H G F E D C B A